

CBCS SCHEME

USN

--	--	--	--	--	--	--	--

15ENG25

Second Semester B.Arch. Degree Examination, Aug./Sept. 2020 Building Structures – II

Time: 3 hrs.

Max. Marks: 100

Note: Answer any FIVE full questions, choosing ONE full question from each module.

Module-1

- 1 a. Explain the following briefly:

(i) Centroid	(ii) Moment of inertia	(iii) Section modulus
(iv) Radius of gyration		

(10 Marks)
- b. Locate the centroid for the figure shown below: (10 Marks)

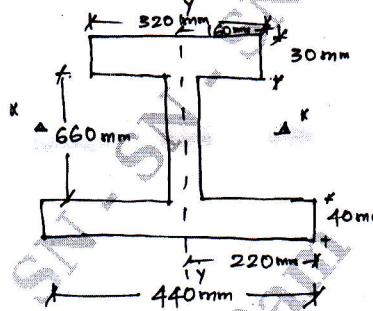

Fig. Q1 (b)

OR

- 2 a. Derive parallel axis theorem. (10 Marks)
- b. Find moment of inertia along X-X axis as indicated in the Fig. Q2 (b). (10 Marks)

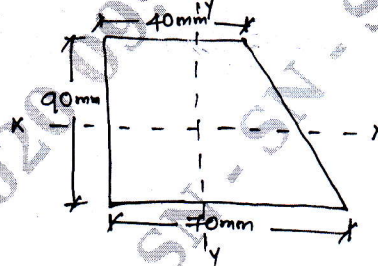

Fig. Q2 (b)

Module-2

- 3 a. Explain shear force diagram and bending moment diagram with sign conventions. (06 Marks)
- b. Draw shear force diagram and bending moment diagram for the following figure Fig. Q3(b). (14 Marks)

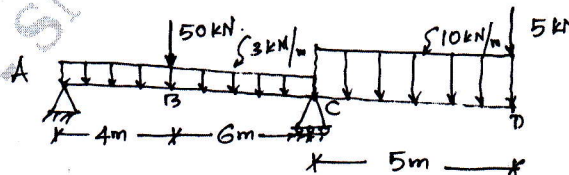

Fig. Q3 (b)

1 of 3

Important Note : 1. On completing your answers, compulsorily draw diagonal cross lines on the remaining blank pages.
2. Any revealing of identification, appeal to evaluator and /or equations written eg. 42+8 = 50, will be treated as malpractice.

OR

- 4 a. Derive bending equation. (10 Marks)
 b. A Cantilever is 3 m long with 150×230 mm rectangular cross-section carries a concentrated load of 40 kN at the end. What maximum bending stress will be developed at the base of the cantilever? (10 Marks)

Module-3

- 5 a. A simply supported beam spans 4 m and carries Udl of 2 kN/m. Compare stresses for the following sections taking moment of inertia along X-X axis as indicated. (14 Marks)

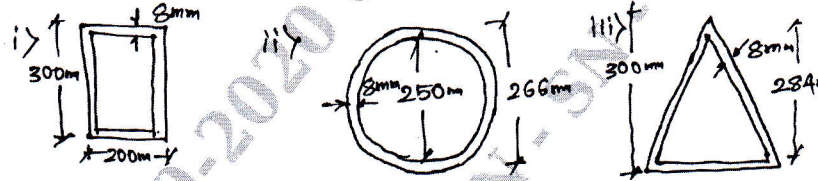

Fig. Q5 (a)

- b. Find the section modulus for the above figures at maximum compressive stress level. (06 Marks)

OR

- 6 a. A timber beam spans 4 m carries a Udl of 4 kN/m, 100×200 mm timber section is used if the modulus of elasticity in the timber is $E = 0.125 \times 10^5$ N/mm². Find the maximum deflection in the timber beam. (10 Marks)
 b. A simply supported steel beam shown in Fig. Q6 (b) is used to span 5 m and carries a load of 25 kN/m including its own weight. Calculate the maximum deflection in the beam. If modulus of elasticity is $E = 2.1 \times 10^5$ N/mm² (10 Marks)

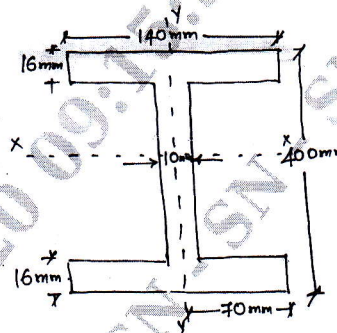

Fig. Q6 (b)

Module-4

- 7 a. What is the difference between short column and long column? (06 Marks)
 b. Determine Euler's crippling load for an I-section column $400 \times 200 \times 10$ mm having length of 5 m. Which is used as strut with both ends fixed. Take $E = 2.1 \times 10^5$ N/mm². (14 Marks)

OR

- 8 a. What is slenderness ratio? How does this affect the design of column? (06 Marks)
 b. Determine the section of a cast iron hollow cylindrical column 3 m long with both ends firmly built in. It carries a working Axial load of 800 kN. The ratio of internal to external diameter is $\frac{5}{8}$. Use factor of safety as 4. (14 Marks)

Module-5

- 9 The cross section of a short axially loaded square concrete column is 500×500 mm with 8 vertical bars of 12 mm ϕ . Determine the strength of column with respect to steel and concrete separately for the given stresses in steel and concrete.

Stresses are ,

(i) $f_y = 415 \text{ N/mm}^2$, $f_{CK} = 20 \text{ N/mm}^2$

(ii) $f_y = 500 \text{ N/mm}^2$, $f_{CK} = 25 \text{ N/mm}^2$

(iii) $f_y = 250 \text{ N/mm}^2$, $f_{CK} = 15 \text{ N/mm}^2$

f_y - Stress in steel, f_{CK} - Stress in concrete

(20 Marks)

OR

- 10 A short axially loaded circular column of 350 mm diameter is reinforced with 6 longitudinal bars of 20 mm ϕ . Determine the strength of concrete and steel with the following data:

(i) $f_y = 250 \text{ N/mm}^2$, $f_{CK} = 15 \text{ N/mm}^2$

(ii) $f_y = 415 \text{ N/mm}^2$, $f_{CK} = 20 \text{ N/mm}^2$

(iii) $f_y = 500 \text{ N/mm}^2$, $f_{CK} = 25 \text{ N/mm}^2$

f_y - Stress in steel, f_{CK} - Stress in concrete

(20 Marks)
